

A1/A3 Class Sound Decoder Specifications

Operation	
Control Modes	DC and DCC. (Sound only available in DCC mode. i.e. no sound support under DC operation)
Electrical Limits	
Track Voltage Maximum	27V
Motor Current - Maximum Continuous	500mA (overload/short circuit protection)
Motor Current - Peak	1A (No function load)
Function Output Current - Maximum	100mA (Unprotected)
Decoder Current - Maximum Total Continuous	800mA (Shared i.e. motor + functions)
Sound and other Functions	
Number of Spot Sound Functions	15
Number of Running Sounds	3 (i.e. Steam Exhaust/Coasting/Idle)
Number of Digital Functions (Lighting)	3 (Headlight/rear Light and Auxiliary)
Audio Amplifier Output	Class D. Power 1.68W @ 8 ohm
Speaker Impedance & Power Rating	8Ω 1 Watt
Number of Sound Channels	2
Physical	
Speaker Diameter	28mm
Dimensions Sound Decoder	25mm x 14mm x 5mm
Termination	8 Pin Plug NEM652 NMRA

WARNING Not suitable for children under 36 months. Handle with care. Please retain these details and the address for future reference.



HORNBY HOBBIES

Hornby Hobbies Ltd. 3rd Floor, The Gateway,
Innovation Way, Discovery Park, Sandwich, CT13 9FF, UK.
Tel: +44 (0) 1843 233525

For more information visit: www.hornby.com

4/1505A

HORNBY®



DIGITAL
TTS SOUND
TWIN TRACK SOUND

A1/A3 Class

Sound Decoder Manual

For more information visit: www.hornby.com

HORNBY®

Contents

1. Introduction	P2
2. Using the Sound Functions etc.	P3
3. Lighting Control	P3
4. CV Notes	P5
5. The Mixer Section	P7
6. Driving Hints and Tips	P8
7. Decoder Plug and Socket connections specification	P10
8. Troubleshooting	P11

1. Introduction

The Hornby A1/A3 Class is fitted with a "Hornby 'Twin Track Sound' decoder" which offers adjustable motor control and a range of realistic sounds including full acceleration/deceleration sounds, whistles and other appropriate locomotive noises associated with the A1/A3 locomotive.

Main Features

- Supports Short and Long decoder addresses.
- Adjustable Acceleration and Deceleration.
- Back EMF Load Compensation.
- Two different selectable and fully adjustable motor control methods for optimal motor control.
- Two sound channels allowing for simultaneous play of full locomotive steam exhaust sounds (chuff) and coasting, while using individual sounds e.g. Whistles, Brakes, Coal Shovelling, Wheel Slip, Injectors, etc.
- A total of 15 different 'spot sounds' in addition to the locomotive's steam exhaust and deceleration sounds are available. When the locomotive is stationary an idle steam sound is played.
Note: Only one of the 15 individual 'spot sounds' may be played at a time.
- When the locomotive is cruising at a constant speed there is a switchable option to either have "Steam exhaust" sounds (chuffing) or the sound of the locomotive 'Coasting' under its own momentum, thus, giving added realism to the sounds the locomotive makes in action. See driving tips for more details.
- It is possible to alter the volume of each sound through an individual dedicated CV, i.e. there is effectively a simple volume mixer on board the decoder. The Volume may be adjusted in 9 steps, 0-8.
- The decoder is equipped to support Front and Rear Light operation via F0 on the controller providing the locomotive is equipped with lighting connected to hardware function Channels 1 and 2 of the decoder.
- The decoder is equipped with 1 Aux function output controlled by F18 on the controller. (This is hardware function Channel 3 on the decoder.)
- IMPORTANT: The decoder does not support sound under DC operation. Sounds can only be played under DCC operation. This statement applies to all sounds both running and individual.
See the Function List in Section 2 for a complete list of decoder features.

For more information visit: www.hornby.com

2. Using the Sound Functions etc.

- Background and steam exhaust plus deceleration sounds are activated by F1 on the controller. Individual sounds can be played at any time without the idle/steam exhaust/deceleration sounds being active. This is achieved by activating the appropriate Function on the controller (F2-F16).
- Some individual sounds play once for a short duration e.g. 'whistles', while other sounds play continuously until deactivated i.e. they are 'Looped' sounds.

Function List. Sound & Lighting (lighting if fitted to loco)

F#	Description	Play Structure
F0	Headlight/Rearlight (Standard decoder function if lights are fitted)	Dependent on locomotive direction
F1	Background Steam/Steam exhaust /Coasting ON-OFF	Various
F2	Whistle 4 Bursts	Plays Once
F3	Whistle 2 Bursts	Plays Once
F4	Whistle Short Burst	Plays Once
F5	Door Slamming	Plays Once
F6	Wheel Slip	Plays Once
F7	Coal Shovelling	Loops until disabled
F8	Blow Down	Loops until disabled
F9	Safety valve	Loops until disabled
F10	Injector	Loops until disabled
F11	Cylinder Cock	Loops until disabled
F12	Brake	Plays Once
F13	Blower	Loops until disabled
F14	Guards Whistle	Plays Once
F15	Coupler Clank	Plays Once
F16	Fireman's Breakfast	Loops until disabled
F17	Toggle Sound Mode between 'Chuffing' and 'Coasting'	Various
F18	Aux Lighting. (Standard decoder function if Aux lights are fitted)	Dependent on user

Please note

Some controllers only offer 'toggle' control for function activation. i.e. Once the function key is pressed it remains 'On'.
If a specific sound is designed to play once for a predetermined duration, the function key will need to be pressed again to return the controller to 'Function Off' status before it is possible to activate the same function again. e.g. the Hornby 'Select' operates in this manner while the Hornby 'Elite' has both 'toggle' and 'momentary' control of functions, which is ideal for controlling both 'Play Once' and 'Looped' spot sounds.

3. Lighting Control Only if loco is equipped with lights etc.

The TTS decoder fitted to your locomotive supports lighting control as standard. However, the following functions are only available if lighting is fitted to the locomotive.

- Front and Rear Lights are activated by F0 on the controller. (Decoder hardware function outputs 1 and 2.)
- The Auxiliary Function output is activated by F18 on the controller. (Decoder hardware function output 3.)



Full CV Table

CVs... A1/A3 Class Running Parameters & Decoder setup

CV	Default Value	Value Range	Description	
CV1	3	1-127	Short decoder address (1-127)	
CV3	15	0-255	Acceleration	See CV Notes
CV4	15	0-255	Deceleration	
CV7	1	Read only	Decoder Firmware Version	
CV8	48	Read only**	Manufacturer ID ***(All Reset = 8) (Sound Volume Reset Only = 5)	
CV10	128	1-128	Back EMF cut off point.	See CV Notes
CV17	192	192-231	Long address high byte	
CV18	100	0-255	Long address low byte	(128 - 10239)
CV29	6	0-48	Decoder Configuration	
CV150	0	0-1	Motor algorithm 1 & 2	
CV151	255	0-255	P1, parameter of Motor algorithm 1	See CV Notes
CV152	1	0-255	I1, parameter of Motor algorithm 1	
CV153	215	0-255	P2, parameter of Motor algorithm 2, reserved	
CV154	115	0-255	I2, parameter of Motor algorithm 2, reserved	
CV159	137	Read only	Decoder sound ID	
CV201	25	70	Loco Start delay 0 = No delay 70 = 7 Seconds Delay	

Volume Settings (Mixer Section)

See section 7 on page 7 'The Mixer Section' for CV explanations, etc.

CV	Default Value	Value Range	A1/A3 Class Sound CV Description
CV160	4	0-8	Volume Locomotive Background Steam and Cylinder Cocks on start
CV161	4	0-8	F1 Volume Locomotive Running - Exhaust/Chuffing while Accelerating/Cruise
CV162	4	0-8	F2 Volume Whistle 4 Bursts
CV163	4	0-8	F3 Volume Whistle 2 Bursts
CV164	4	0-8	F4 Volume Whistle Short Burst
CV165	4	0-8	F5 Volume Doors Slamming
CV166	4	0-8	F6 Volume Wheel Slip
CV167	4	0-8	F7 Volume Coal Shovelling
CV168	4	0-8	F8 Volume Blow Down
CV169	4	0-8	F9 Volume Safety Valve
CV170	4	0-8	F10 Volume Injector
CV171	4	0-8	F11 Volume Cylinder Cock
CV172	4	0-8	F12 Volume Brake
CV173	4	0-8	F13 Volume Blower
CV174	4	0-8	F14 Volume Guards Whistle
CV175	4	0-8	F15 Volume Coupler Clank
CV176	4	0-8	F16 Volume Fireman's Breakfast
CV177	4	0-8	F1 Volume Locomotive Running - Decelerating (Cruise, Sound Mode 2)
CV178	Not Readable	0-8	Quick Set Volume level

For more information visit: www.hornby.com

4. CV Notes

CV3 and CV4 Acceleration and Deceleration

Any value less than the default of '15' is likely to cause steam exhaust and deceleration (coasting) sound playback to operate incorrectly.

CV8 Manufacturers ID and Reset

If read, this CV will report the manufacturer's ID for Hornby Hobbies 48. Writing the value '8' to CV8 will perform a 'general reset' of all CV variables to factory default values.

The decoder also has a unique feature, i.e. writing the value '5' to CV8 will reset all sound volume levels to default levels, i.e. CV160 to CV177 will be returned to default values. All other CV values (non-sound related) will be left as programmed by the user.

CV10 Back EMF Cut-Off Point

The decoder supports 'load' compensation. This is a feature that tries to maintain a constant speed of the locomotive as the load on the motor changes, i.e. when negotiating inclines and curves, etc.

This is achieved by monitoring the actual speed of the motor via the motors BEMF (Back Electromotive Force) and comparing the voltage level detected to the Speed Step command sent to the decoder. Speed Steps are in the value range 1-128. Using this CV allows a cut-off point to be set for the Speed Step value where the BEMF load compensation action ceases to be applied.

Generally this value is left as default (128). In some rare cases adjustment of this CV can assist smoothness of lower speed running.

Example: If the CV is set to a value of 100, the load compensation will not be applied above Speed Step 100.

CV29 Decoder Basic Configuration

The supported functions are:

Ref	Function	Add this value to activate function
Bit0	Default Direction Control ~ Normal or Reversed	Add 1 to reverse direction
Bit1	Speed Step Lighting Direction Command 14 or 28/128	Add 2 to use 28/128 mode
Bit2	DCC Only or DCC and DC Running	Add 4 to enable both DC and DCC Running
Bit5	Long or Short Address	Add 32 if required to manually control long address selection

Add the desired values for each function to obtain the needed value of CV29.
Example: The default value for CV29 is 6, i.e. 28/128 Speed Steps + Enable analogue operation = 2+4 = 6.





Further notes re CV29

Bit0 (Add 1 to activate) is used to control the default direction of the locomotive. This is useful if the decoder has been retro fitted to a non-DCC fitted locomotive and a wiring error has been made re connection to the motor. Other uses are where the model railway layout requires reversed direction operation.

Bit1 (Add 2 to activate) is used to set the decoder to detect the correct location of the direction command for lighting control, i.e. whether the decoder is expecting 14 or 28/128 Speed Steps. It is not usual to edit this feature as the decoder will handle this function automatically in most cases.

Bit2 (Add 4 to activate) is used to control whether the decoder will operate on both DC and DCC layout control. By default both forms of power are enabled. It is recommended if only running on a DCC controlled layout to turn off DC operation, i.e. CV29 = 2 if only changing this feature of CV29.

Bit5 (Add 32 to activate) The decoder stores Short Addresses in CV1 and Long Addresses in CV17 and CV18. Bit5 is used to tell the decoder where to find its allocated address, i.e. for Long Addresses Bit5 is enabled. This feature is usually handled automatically, it is not usually necessary to edit the value of this Bit.

Please Note

If a decoder is returned to default settings, i.e. address 03, etc., if Bit5 is turned 'on' to make the decoder operate in 'Long Address' mode, the decoder will respond to address 100. Turning Bit5 to the 'off' state will return the decoder to 'Short Address' mode, i.e. address 03.

If the decoder has been previously used with both Short and Long Addresses toggling this Bit on/off allows the decoder to use either the Short or Long Address previously programmed.

CV150-154: Motor Control Method

Motor speed control is achieved using a controlled loop system (algorithm) where the decoder checks the speed of the motor and compares the retrieved current speed information of the motor with the 'desired' speed setting, e.g. if the locomotive is climbing a hill, the tendency is for the locomotive to slow down compared to the desired speed set from the controller.

The control system will detect this and try to compensate the speed drop by increasing the drive to the motor. Similarly, when a locomotive moves off from standstill, the control system will try to compensate for the tendency for the locomotive to remain static (inertia at rest).

The control algorithms employed are referred to as PIDs. This refers to Proportional - Integral - Differential. Further explanation is outside the scope of these notes but from the point of view of this note it is the P and I factors that interest us, as follows.

How the decoder reacts and controls the compensation system for speed drops, etc. can be adjusted. Adjustment of the motor drive characteristics is carried out with the following CVs. CV150 allows the selection of one of two base motor control algorithms. The CV value range is 0-1.

This corresponds with: CV150=0 Algorithm 1 is in control.

CV150=1 Algorithm 2 is in control.

Each of the two algorithms can be further adjusted by use of their associated CVs.

Motor control Algorithms: Description

Algorithm 1 (CV150=0)

This algorithm is a non-linear curve which offers lower controlled speed in the low speed end of the curve. This is similar to the Hornby decoder type R8249. CVs 151 & 152 offer control of the P and I factors of the Algorithm (1).

Generally speaking the higher the setting for these two values the motor control becomes 'Stronger' but at the cost of losing fine control. By default this algorithm is set with the P and I value set to 255 and 1 respectively.

Algorithm 2 (CV150=1)

This algorithm is a linear curve which offers higher controlled speed in the low speed end of the curve. This is similar to some Lenz type decoders.

CVs 153 & 154 offer control of the P and I factors of Algorithm 2.

By default this algorithm is set with P and I values of 215 and 129 respectively.

Note that CV10 (BEMF cut off) also affects motor control performance.

CV201: Locomotive Start Delay

When the locomotive starts there is a particular sequence of sounds played, i.e. Back Ground Idle steam will fade in to the sound of the cylinder cocks, then chuffing will commence. This CV controls when the locomotive actually starts to move after the throttle is applied from stationary. The default is 2.5 seconds. When left in default settings the locomotive will move just about halfway through the cylinder cock sound. The maximum delay duration is 7 seconds. The value range for this CV is 0-70. Zero being no delay and 70 being the maximum value of 7 seconds.

5. The 'Mixer' Section. Adjusting the decoder's Sound Volumes via CVs

CV160 to CV178: Description

6 7 CV160 through to CV178 control the relative volume levels of the played back sounds.

Volume Settings (Mixer Section)

CV	Default Value	Value Range	AI/A3 Class Sound CV Description
CV160	4	0-8	Volume Locomotive Background Steam
CV161	4	0-8	F1 Volume Locomotive Running - Exhaust/ Chuffing while Accelerating/Cruise
CV162	4	0-8	F2 Volume Whistle 4 Bursts
CV163	4	0-8	F3 Volume Whistle 2 Bursts
CV164	4	0-8	F4 Volume Whistle Short Burst
CV165	4	0-8	F5 Volume Doors Slamming
CV166	4	0-8	F6 Volume Wheel Slip
CV167	4	0-8	F7 Volume Coal Shovelling
CV168	4	0-8	F8 Volume Blow Down
CV169	4	0-8	F9 Volume Safety Valve
CV170	4	0-8	F10 Volume Injector
CV171	4	0-8	F11 Volume Cylinder Cock
CV172	4	0-8	F12 Volume Brake
CV173	4	0-8	F13 Volume Blower
CV174	4	0-8	F14 Volume Guards Whistle
CV175	4	0-8	F15 Volume Coupler Clank
CV176	4	0-8	F16 Volume Fireman's Breakfast
CV177	4	0-8	F1 Volume Locomotive Running -While Decelerating (coasting)
CV178	Not Readable	0-8	Shortcut: Quick Set Volume level

For more information visit: www.hornby.com

CV178 controls the general volume of all locomotive sounds. There are 9 possible settings, i.e. 0-8. 0 is no sound, while 8 is full volume. The sound set of the locomotive has been balanced in the factory so that sounds play at the correct volumes relative to each other. However, individual sounds may be fine-tuned in volume by the user to suit by adjusting their associated CV... see table.

Setting up volumes using the 'Mixer' Section

It is recommended that the following CV adjustment procedure is executed in 'Operate Mode' with the locomotive on the 'Main' track. This is sometimes referred to as 'Programming on the Main'. Using this programming method greatly speeds up the process of setting the sound balance of the decoder. However, please note you will need to return the locomotive to the 'Programming Track' and use 'DIRECT CV' Programming mode in order to read back any CV values.

Suggested Sound Volume Set-up Procedure

Start by setting up the general locomotive volume level by adjusting CV178 until the volume level of the locomotive 'Steam Exhaust' is at the desired level while the locomotive is running at slow to moderate speed.

The sounds on board the locomotive decoder have been preset in volume to give a 'balanced' sound at whatever volume CV178 is set at. However, each individual sound component can now be adjusted in volume to suit.

The associated CV number for each locomotive sound can be found on the CV table on page 7.

If you become confused while adjusting the sound volumes the following will assist:

CV8. Apart from the usual 'general reset' function common to all Hornby decoders (CV8=8) on the sound decoder CV8 has a secondary function i.e. writing the value '5' to CV8 will reset all sound volume levels to default levels i.e. CV160 to CV177 will be returned to default values i.e. 4. All other CVs will be left as programmed by the user.

Once you are more familiar with the sound volume set up procedure you will find that it is very easy to set a sound volume levels while the locomotive is on the Main track. This technique allows you to instantly hear the sound volume change as the associated CV is edited. Please see your DCC controller manual re programming in 'Operational Mode' or 'Programming on the Main'.

Note, if you wish to read back any CV setting you must place the locomotive on the 'Programming Track'.

6. Driving Hints and Tips: Making the most of the sounds

Locomotive Running Sounds

Generally, a locomotive pulling a rake of coaches will make loud 'Chuffing' sounds when cruising (constant speed) and accelerating. Negotiating an incline under load the locomotive will also make loud or heavy chuffing noises. In these cases the locomotive is working hard. On the flat, or when going 'downhill' a locomotive may not make any real 'chuffing' sounds at all as it is cruising under its own momentum. In this case the locomotive is not working so hard.

In the TTS decoder we have included the ability to toggle the sound system between two modes for added realism while driving your loco... Use F17 to toggle between the two different sound modes.

F17 OFF... This is the default mode i.e. Steam Exhaust 'chuffing' sounds are played all the time the locomotive is accelerating or at constant speed.

F17 ON... In the second mode (Cruise Mode) all Steam Exhaust 'chuffing' sounds are replaced with the same sound set that is used when the locomotive is decelerating i.e. (wind noise, wheels etc.) The locomotive sound varies as the locomotive speed changes.

Note, if you intend to use the two different sound modes selected by F17, you may wish to set the volume level of the "deceleration" sounds (CV177) slightly higher than the 'acceleration' sounds (CV160). It is a matter of personal preference.

Typically, 'Cruise Mode' may be activated when running downhill or at high constant speed on the flat. Use F17 to return to default mode for short bursts of power to maintain constant speed on the flat or for long durations when negotiating an incline or pulling a heavy load. Switch between these two sound modes to give a realistic experience of the locomotive's operation.

Function Control

By careful manipulation of the various Function controls on the DCC controller it is possible to simulate a 'realistic' driving experience. It is recommended that you study the full list of sound functions (See table below) and familiarise yourself as to which are 'Loop' play sounds and those that 'Play Once' for a specific duration.

It is recommended that you do this as it may have some bearing on how you use your controller. See previous note in Section 2 on page 3 regarding controllers that do not support 'momentary' action function control.

For a 'realistic driving experience' try the following procedures and sounds.

For a 'realistic' driving experience we suggest that when going from stationary to speed that you at first apply enough throttle to get the locomotive moving. When the locomotive first moves off, the sound of the cylinder cocks will be heard, then steam exhaust 'chuffing' commences. Once the locomotive is moving you can open the throttle to accelerate the locomotive to the desired speed. Below are some suggestions as to when certain sounds activated by the Function controls listed below might occur during locomotive operations in 'real life'.

F#	Sound Description	Play Structure
F1	Background Steam/Cylinder Cock/Steam exhaust/Coasting ON-OFF	Various
F2	Whistle 4 Bursts	Plays Once
F3	Whistle 2 Bursts	Plays Once
F4	Whistle Short Burst	Plays Once
F5	Doors Slamming	Plays Once
F6	Wheel Slip	Plays Once
F7	Coal Shovelling	Loops until disabled
F8	Blow Down	Loops until disabled
F9	Safety valve	Loops until disabled
F10	Injector	Loops until disabled
F11	Cylinder Cock	Loops until disabled
F12	Brake	Plays Once
F13	Blower	Loops until disabled
F14	Guards Whistle	Plays Once
F15	Coupler Clank	Plays Once
F16	Fireman's Breakfast	Loops until disabled
F17	Toggle Sound Mode between 'Chuffing' and 'Coasting'	Various

For more information visit: www.hornby.com

When moving off the following sounds are commonly heard in the following order...

Please note: There will be a short pause before the locomotive moves off as you hear the sound of steam entering the cylinders, the sound will then change to the familiar sound of 'steam exhaust' i.e. chuffing.

- Doors Slamming (F5) Guards Whistle (F14) and then open the Cylinder Cocks (F11)
- Whistle (F2 or F4)
- Turn Throttle Control slightly, until locomotive starts to move
- Apply a little Wheel Slip (F6)
- Shut Cylinder Cocks (F11)
- If desired, Turn Throttle Control to set the locomotive speed

Other sounds that may be heard...

Blower (F13), Coal Shovelling (F7) Occasionally Safety Valve (F9)

When the locomotive is running the following sounds are commonly heard...

Safety Valve (F9), Injectors (F10), Blower (F13) followed immediately by Coal Shovelling (F7), Whistle (F2 - F4)

Also, try toggling between the two locomotive running sound modes.. i.e. use F17 to switch between default 'chuffing' mode and 'cruise' mode sounds. See previous explanation for more information.

When the locomotive is stopping...

When the locomotive is almost at rest apply a little brake squeal (F12)

When the locomotive is stationary e.g. in a station, the following sounds are commonly heard...

Safety Valve (F9), Injectors (F10), Coupler Clank (F15), Blower (F13) followed immediately by Coal Shovelling (F7), Possibly Cylinder Cock (F11)

When the locomotive is in a siding the following sounds are commonly heard:

Blower (F13), Coal Shovelling (F7) Safety Valve (F9), Blow Down (F8). Blow Down is a rarely used boiler cleaning function, and finally, Breakfast (F16)

7. Decoder Plug and Socket connection specification

Decoder Plug / Socket configuration viewed from above (NMRA Standard Configuration)

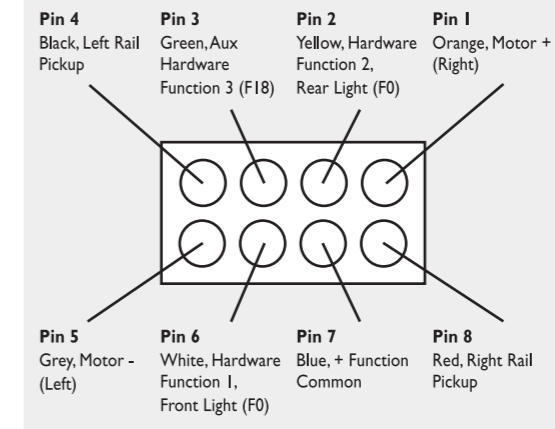

Decoder Current Limits

- Function Output current limits are 100mA per function hardware connection.
- Total Current Draw from decoder is 800mA (motor + functions).
- Decoder can handle 1A peak for short durations. (No Function Load).

Typical example of the configuration of lighting connections regarding function output

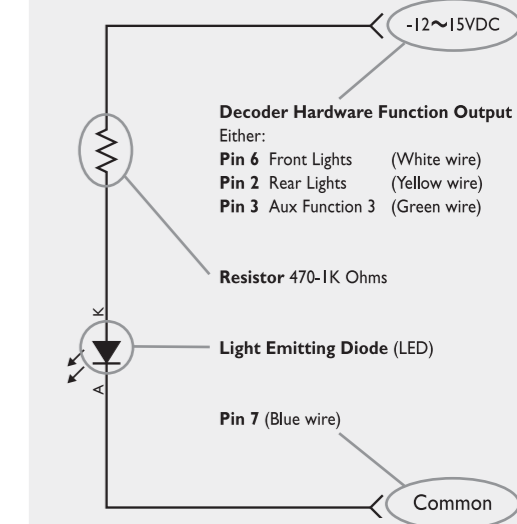

Please note

The Hornby A1/A3 Class is not fitted with lights. The above is standard information for the TTS series of Hornby decoders. If your locomotive is equipped with incandescent light bulbs ('Grain of Rice') please ensure that they are rated a current level below 100mA at 12-15VDC. Most bulbs of this type are rated at approximately 65mA.

8. Troubleshooting

No Sound	Turn on sound (F1). The decoder does not support DC running with sound. Reset Decoder.
Jerky Running	Reset Decoder. Clean Rails / Wheels / Pickups.
No Control from the Locomotive	Check Decoder Address. Reset Decoder. Reset Controller. Clean Rails / Wheels / Pickups.
No Response	Check Decoder Address. Reset Decoder. Reset Controller. Clean Rails / Wheels / Pickups.

For Customer Care contact:
+44 (0)1843 233525
 or via website www.hornby.com