

'Class 60' TTS Sound Decoder and Speaker Specifications

Operation	
Control Modes	DC and DCC. (Sound only available in DCC mode. i.e. no sound support under DC operation)
Electrical Limits	
Track Voltage Maximum	27V
Motor Current - Maximum Continuous	500mA (overload/short circuit protection)
Motor Current - Peak	1A (No function load)
Function Output Current - Maximum	100mA (Unprotected)
Decoder Current - Maximum Total Continuous	800mA (Shared i.e. motor + functions)
Sound and other Functions	
Number of Spot Sound Functions	18
Number of Running Sounds	4 (Idle, Notch 1, Notch 2, Notch 3 and all transitions)
Number of Digital Functions (Lighting)	3 (Headlight/Rear Light and Auxiliary) (When fitted to locomotive)
Audio Amplifier Output	Class D. Power 1.68W @ 8 ohm
Speaker Impedance & Power Rating	8Ω 1 Watt
Number of Sound Channels	2
Physical	
Speaker Diameter	40mm x 20mm
Dimensions Sound Decoder	27mm x 14mm x 5mm
Termination	8 Pin Plug NEM652 NMRA

WARNING Not suitable for children under 14 years of age. Handle with care. Please retain these details and the address for future reference.



Manufactured by: Hornby Hobbies Ltd, Westwood Margate, Kent, CT9 4JX, UK
EU Authorised Representative: Hornby Italia SRL Viale dei Caduti, 52/A6, Castel Mella (BS), Italy, 25030

Tel: +44 (0) 1843 233525

For more information visit: www.hornby.com

4/1532A

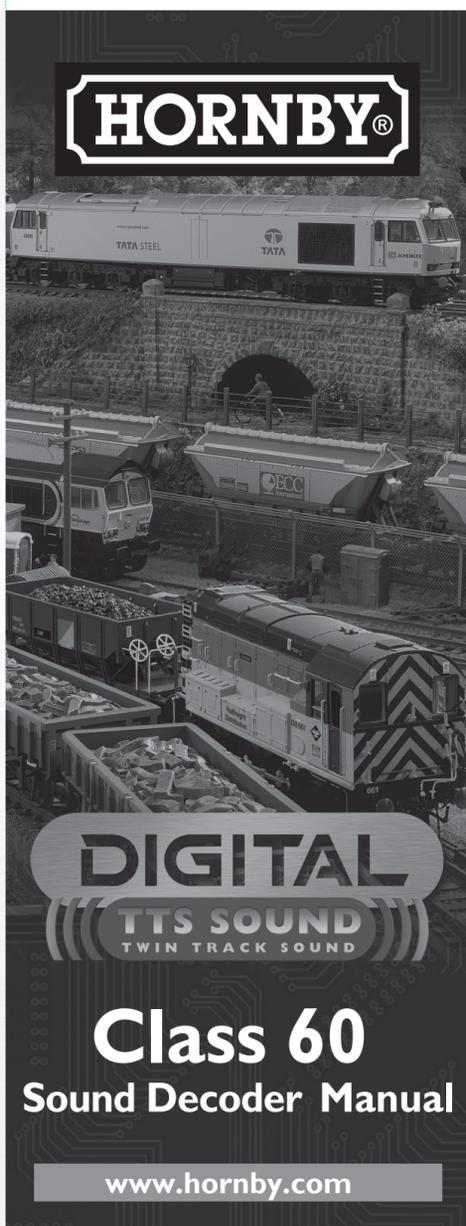

Class 60 Sound Decoder Manual

www.hornby.com



Contents	
1. Introduction	2
2. Function List	3
3. Understanding Diesel/Electric locomotives	4
4. Driving & controlling the engine of your TTS Diesel Locomotive	4
5. CV Table 1:	6
6. CV Table 2: Engine Sound Transition Configuration	9
7. CV Table 3: Spot Sounds Volume Configuration	12
8. Decoder Plug and Socket connection specification	14
9. Glossary Function Sounds	15
10. Troubleshooting	15

I. Introduction

The Hornby 'Class 60' diesel/electric locomotive is fitted with a 'Hornby Twin Track Sound decoder' which offers adjustable motor control and a range of realistic engine sounds including full acceleration/deceleration sounds, horns, and other appropriate locomotive noises associated with the 'Class 60' locomotive.

Main Features

- Supports Short and Long decoder addresses.
- Adjustable Acceleration and Deceleration.
- Back EMF Load Compensation.
- Automatic or manual adjustable engine control methods. Both methods can be used together for realistic engine control.
- Two sound channels allowing for simultaneous play of full locomotive diesel engine sounds, and individual spot sounds e.g. Horns, Whistles, Brakes, Engine start, wagons clanging and coupling etc.
- A total of 18 different 'spot sounds' in addition to the locomotive's diesel motor start/stop and running sounds are available.
Note: Only one of these individual spot sounds may be played at the same time.
- Authentic start-up sounds for the 'Class 60'. You can choose between warm or cold start up. Loco start is activated by F1 on the controller. If F9 is previously selected the loco will perform a 'Cold Start'. Loco engine sounds are turned off by selecting F1 again. Individual spot sounds (horns etc.) can be played at any time without the locomotive's engine sound being interrupted.
- It is possible to alter the volume of each sound through an individual dedicated CV. i.e. there is effectively a simple volume mixer on board the decoder. Volume may be adjusted in 8 steps, 0-8.
- The decoder is equipped to support directional Front and Rear Light operation via F0 on the controller providing the locomotive is equipped with lighting connected to hardware function channels 1 and 2 of the decoder. Note: The Class 60 TTS does have lights installed.
- The decoder is equipped with 1 aux function output controlled by F25 on the controller. (This is hardware function channel 3 on the decoder.) Note: The Class 60 has nothing connected to the aux output.
- **IMPORTANT** The decoder does not support sound under DC operation. Sounds can only be played under DCC operation. This statement applies to all sounds both running and individual spot sounds. The locomotive's motor may be controlled under DC operation. See the Function List in Section 2 for a complete list of decoder features.

For more information visit: www.hornby.com

2. Function List

Engine Sound Control and Lighting

F#	Sound Description	Play Structure
F0	Headlight/Rear-Light	Toggle On/Off (Loco Direction dependent)
F1	Engine Start/Stop	Various (Toggle On/Off)
F2	Horn Low-High	Plays Once (Momentary Action)
F3	Horn High-Low	Plays Once (Momentary Action)
F4	Brake Squeal	Plays Once (Momentary Action)
F5	NOTCH Up	Activates on Momentary Switch Control
F6	NOTCH Down	Activates on Momentary Switch Control
F7	Return to IDLE	Activates on Momentary Switch Control
F8	Thrash	Toggle On/Off
F9	Cold Start Override	Toggle On/Off
F10	Compressor	Plays until disabled (Toggle On/Off)
F11	Door Slam	Plays Once (Momentary Action)
F12	Fan	Plays until disabled (Toggle On/Off)
F13	Horn High Low High	Plays Once (Momentary Action)
F14	Horn Low High Low	Plays Once (Momentary Action)
F15	Primer	Plays until disabled (Toggle On/Off)
F16	Slow Flange Squeal	Plays until disabled (Toggle On/Off)
F17	Spirax Valve	Plays until disabled (Toggle On/Off)
F18	Horn Low	Plays Once (Momentary Action)
F19	Horn High	Plays Once (Momentary Action)
F20	Wagons Buffering	Plays Once (Momentary Action)
F21	Wagons Clanging	Plays Once (Momentary Action)
F22	Coupling	Plays Once (Momentary Action)
F23	Guards Whistle	Plays Once (Momentary Action)
F24	Buffering	Plays Once (Momentary Action)
F25	Aux (if used in locomotive)	Toggle On/Off

Note Regarding Toggle and Momentary Action Function Control. (Check your controller manual!)

Some controllers only offer 'toggle' control for function activation. i.e. Once the function key is pressed it remains 'On'. If a specific sound or function is designed to play/activate once, the function key will need to be pressed again to return the controller to 'function off' status before it is possible to activate the same function again, e.g. the Hornby 'Select' operates in this manner while the Hornby 'Elite' has both 'toggle' and 'momentary' control of functions, which is ideal for controlling both 'Play Once/Activate Once' and 'Looped' spot sounds.

Note re Lighting Control. (Only if loco is equipped with lights etc.)

The TTS decoder fitted to your locomotive supports lighting control as standard. However, the following functions are only available if lighting is fitted to the loco.

- Front and Rear Lights are activated by F0 on the controller. (Decoder hardware function outputs 1 and 2 using the decoder's yellow and white wires.)
- The Auxiliary Function output is activated by F25 on the controller. (Decoder hardware function output 3 using the decoder's green wire.)



3. Understanding Diesel/Electric locomotives

How does a diesel/electric locomotive work?

Although the real locomotive has a diesel engine, this engine does not directly drive the locomotive's wheels. The engine is used to turn a generator which provides electricity for electric motors (traction motors) that drive the locomotive's driving wheels. As such the driver does not control the locomotive's speed with a direct throttle like a car, rather the driver will Notch the diesel engine up and down; thus varying the amount of power available to the traction motors in response the amount of effort needed at any time to move or maintain the speed of the locomotive. Typically, when he moves off with a load or encounters an incline etc he will notch the revs of the engine upwards. When the locomotive is rolling after initial acceleration he may well 'Notch down' (Notch back) the diesel engine. Due to the nature of the diesel electric control system there is a noticeable degree of lag between the locomotive's physical speed and the engine revs commanded by the driver.

When shunting heavy loads the driver may carry out 'Thrashing' of the locomotive's engine i.e. applying bursts of high revs rather than just simply Notching the diesel engine upwards. Thrashing can be thought of as the driver 'stamping on the throttle'. F8 allows you to thrash the locomotive's engine. The action of F8 is that the engine will increase its current running notch by a two notches, where possible. See explanation under Manual Control later in this manual.

4. Driving & controlling the engine of your TTS Diesel Locomotive

Automatic Engine Control

The TTS locomotive will rev up and down (notching) automatically depending on the throttle applied to the locomotive. For basic use it is not necessary to fully understand how the sound system selects the appropriate sound to be played. If you wish to understand fully how the 'automatic' system work please see 'CV table 2: Engine Sound Transition Configuration' on page 10. Using the CV table on page 10 it is possible to tune the automatic system to suit the way you wish to drive the locomotive. But for now, until you get used to how your locomotive works, we suggest leaving these adjustments in their default values. The automatic system can be overridden at any time by using the manual control engine control functions.

Manual Engine Control

Generally, the locomotive engine will carry out automatically the transition between different levels (Notches) of the diesels rev range dependent on the speed step applied from the DCC controller. The automatic process can be overridden or modified by the use of the NOTCH up/down functions (F5 & F6) or by the specialist control features 'Thrash' (F8) and 'Return to IDLE' (F7). Please note in the following table describes how each engine control function is designed to work.

F5	NOTCH Up	Activates on Momentary Switch Control... DO NOT USE TOGGLE... See note on page 2
F6	NOTCH Down	Activates on Momentary Switch Control... DO NOT USE TOGGLE... See note on page 2
F7	Return to IDLE	Activates on Momentary Switch Control... DO NOT USE TOGGLE... See note on page 2
F8	Thrash	Toggle On/Off (All throttle changes are ignored except F7 when 'Thrash' is enabled. See page 5.)

For more information visit: www.hornby.com

Caution regarding loss of automatic or manual engine control. Please READ THIS!

If you are using any type of controller that does not indicate the status of a function i.e. there is no display telling you whether a function is enabled (on) or disabled (off) or a controller that only offers 'toggle' function control; then it is possible that you could become confused re the set state of control of the engine sound e.g. the automatic notching up and down process will cease to work because you have inadvertently left F8 (Thrash) in a permanent 'on' state. Leaving other engine controls i.e. F5 (Notch Up), F6 (Notch Down) and F7 (Return to Idle) will not cause permanent loss of the automatic control but, they will not activate when commanded as they must be returned to the 'off' state before they can be re-activated.

The above can be very confusing and lead the user to wrongly think there is a fault with the TTS decoder.

Solution : A quick and simple solution to diagnose whether you have left a function "enabled" is to simply re programme the decoder to a new address number that has never been used; and see if the decoder engine sound starts to behave correctly again (DO NOT ACTIVATE any engine control functions.)

Note : resetting the decoder or, resetting the controller will not correct this issue. Some controllers may set all function controls to 'disabled' when reset. Please check you controller's documentation.

Driving Tips and suggestions

By careful manipulation of the various Function controls on the DCC controller it is possible to simulate a 'realistic' driving experience. It is recommended that you study the full list of sound functions, and familiarise yourself as to which are 'toggle' control or 'momentary' control. Take note of the 'Loop' play sounds, and those that 'Play Once' for a specific duration. It is recommended that you do this; as it may have some bearing on how you use your controller. See previous note re controllers that do not support 'momentary' action function control.

Start-up ...On pressing F1 (toggle on) the loco engine will warm start and settle to idle revs. If F9 is toggled on before F1 is pressed, the loco will execute a cold start and settle to idle. To shut down the engine press F1 again (toggle off.)
When moving off the loco will automatically play the sound of the pneumatic brake releasing.

When the locomotive is running it is possible to notch up/down using the decoders automatic features by making very small adjustments to the controller's throttle. Because the loco decoder simulates inertia via the acceleration and deceleration setting (see CV's explanations) no apparent change will be made to the locos speed. On each minor deceleration the locomotive's engine will notch down and on an increase of the throttle; the loco will notch up to the most appropriate notch for the locos current speed.

Manual Notch up and Notch Down. It is possible to take control of the locomotive's engine via the controller's function controls. F5 will allow you to Notch up one step. F6 allows you to Notch down one step. Both F5 and F6 are 'momentary' functions.

Thrashing It is possible to take control of the locomotive's engine via the controller's function controls. F8 will allow you to "thrash" the locomotive's engine i.e. the engine will Notch quickly upwards, remain at the new Notch until F8 is released. F8 is a toggle function and overrides any automatic Notching due to throttle changes while active. If F8 is disabled then the locomotive will play the appropriate Notch sound for the locomotive's current speed.

Return to Idle Override F7 is a momentary function which will cause the locomotive engine to return to idle. Until the locomotive engine has returned to idle the system will not respond to any other manual or automatic Notch changes. This function might be used when the locomotive has attained the desired speed and it is immediately required to go to 'coast'.



If F7 is enabled while the loco is in 'Thrash' mode (F8), F8 must be manually turned off/disabled before locomotive engine control can resume.

Note : Sometimes diesel locomotives were used as 'standing generators' e.g. possibly to power plant during engineering works etc. Because the diesel TTS sound system allows independent control of the engine speed from the actual speed of the locomotive, using F8 Thrashing, F5 Notch up, F6 Notch down and F7 Return to Idle; it is possible to run the engine at high revs while the locomotive is stationary.

Tips for Hornby ELITE users ... If you hold any button on the Keypad for more than 3 seconds it automatically operates as a momentary function control. i.e. the function is 'released' after you stop pressing the button.
A single press of the button toggles the function on until it disabled via another button press.

We have found that the best way of using the functions F5 and F6 (Notch Up/Down) and F7 (Return to idle) is to press and hold the appropriate button until you hear the locomotive's engine note change.

F8 Thrashing is a toggle function so it is only necessary to quickly press button 8 to enable the Thrash action. Pressing button 8 again returns the locomotive engine to normal 'automatic' response.

Tip for Hornby SELECT users ... Please note the SELECT does not support 'momentary' action function control. Please read the note on page 3 re using non-momentary control functions.

5. CV Table 1

For clarity we have divided the decoder CV table in to 3 sections.

Table 1 shows the standard decoder configuration CVs.

Table 2 shows the engine sound control parameters.

Table 3 shows the locomotive spot sounds (horns sounds etc) volume settings.

CV table 1: Standard Decoder Configuration

CVs... 'Class 60' Running Parameters & Decoder setup

CV	Default Value	Range	Description
CV1	3	1-127	Short decoder address (Address range 1-127)
CV3	15	0-255	Acceleration
CV4	15	0-255	Deceleration
CV7	xxx	Read only	Decoder Firmware Version
CV8	48	Read only**	Manufacturer ID ** (All Reset = 8) (Sound Volume Reset Only = 5)
CV10	128	1-128	Back EMF cut off point.
CV17	192	192-231	Long address high byte
CV18	100	0-255	Long address low byte
CV29	6	0-48	Decoder Configuration
CV150	0	0-1	Motor algorithm 1 & 2
CV151	8	0-255	P1, parameter of Motor algorithm 1
CV152	8	0-255	P1, parameter of Motor algorithm 1
CV153	215	0-255	P2, parameter of Motor algorithm 2
CV154	115	0-255	P2, parameter of Motor algorithm 2
CV158	xxx	Read only	Decoder Sound Version
CV159	163	Read only	Decoder sound ID

For more information visit: www.hornby.com



CV3 and CV4 Acceleration and Deceleration

Any value less than the default of '15' is likely to cause sound playback to operate incorrectly. You may like to increase the values here for added realism.

CV8 Manufacturers ID and Reset

If read, this CV will report the manufacturer's ID for Hornby Hobbies 48.

Caution : Writing the value '8' to CV8 will perform a 'general reset' of all CV variables to factory default values.

The decoder also has a unique feature, i.e. writing the value '5' to CV8 will reset all sound volume levels to default levels, i.e. CV160 to CV180 will be returned to default values. All other CV values (non-sound related) will be left as programmed by the user.

CV10 Back EMF Cut-Off Point

The decoder supports 'load' compensation. This is a feature that tries to maintain a constant speed of the locomotive as the load on the motor changes, i.e. when negotiating inclines and curves, etc.

This is achieved by monitoring the actual speed of the motor via the motors BEMF (Back Electromotive Force) and comparing the voltage level detected to the Speed Step command sent to the decoder. Speed Steps are in the value range 1-128. Using this CV allows a cut-off point to be set for the Speed Step value where the BEMF load compensation action ceases to be applied.

Generally, this value is left as default (128); but in some rare cases adjustment of this CV can assist smoothness of lower speed running.

Example : If the CV is set to a value of 100, the load compensation will not be applied above Speed Step 100.

CV29 Decoder Basic Configuration

The supported functions are:

Ref	Function	Add this value to activate function
Bit0	Default Direction Control ~ Normal or Reversed	Add 1 to reverse direction
Bit1	Speed Step Lighting Direction Command 14 or 28/128	Add 2 to use 28/128 mode
Bit2	DCC Only or DCC and DC Running	Add 4 to enable both DC and DCC Running
Bit5	Long or Short Address	Add 32 if required to manually control selection of long address stored in CV17 and CV18

Add the desired values for each function to get the needed value of CV29.

Example : The default value for CV29 is 6, i.e. 28/128 Speed Steps + Enable analogue operation = 2+4 = 6.

Read Only CVs that contain version information

Please note the following CVs are subject to change.

CV7	Decoder Version number
CV158	Decoder Sound Version number



Further notes re CV29

Bit0 (Add 1 to activate) is used to control the default direction of the locomotive. This is useful if the decoder has been retro fitted to a non-DCC fitted locomotive and a wiring error has been made re connection to the motor. Other uses are where the model railway layout requires reversed direction operation.

Bit1 (Add 2 to activate) is used to set the decoder to detect the correct location of the direction command for lighting control, i.e. whether the decoder is expecting 14 or 28/128 Speed Steps. It is not usual to edit this feature as the decoder will handle this function automatically in most cases.

Bit2 (Add 4 to activate) is used to control whether the decoder will operate on both DC and DCC layout control. By default both forms of power are enabled. It is recommended if only running on a DCC controlled layout to turn off DC operation, i.e. CV29 = 2 if only changing this feature of CV29.

Bit5 (Add 32 to activate) The decoder stores Short Addresses in CV1 and Long Addresses in CV17 and CV18. Bit5 is used to tell the decoder where to find its allocated address, i.e. for Long Addresses Bit5 is enabled.

This feature is usually handled automatically, it is not usually necessary to edit the value of this Bit.

Please Note

If a decoder is returned to default settings, i.e. address 03, etc., if Bit5 is turned 'on' to make the decoder operate in 'Long Address' mode, the decoder will respond to address 100. Turning Bit5 to the 'off' state will return the decoder to 'Short Address' mode, i.e. address 03.

If the decoder has been previously used with both Short and Long Addresses toggling this Bit on/off allows the decoder to use either the short or long address previously programmed.

CV150-154: Motor Control Method

Motor speed control is achieved using a controlled loop system (algorithm) where the decoder checks the speed of the motor and compares the retrieved current speed information of the motor with the 'desired' speed setting.

For example, if the locomotive is climbing a hill, the tendency is for the locomotive to slow down compared to the desired speed set from the controller. The control system will detect this and try to compensate the speed drop by increasing the drive to the motor. Similarly, when a locomotive moves off from standstill, the control system will try to compensate for the tendency for the locomotive to remain static (inertia at rest).

The control algorithms employed are referred to as PIDs. This refers to Proportional - Integral - Differential. Further explanation is outside the scope of these notes but from the point of view of this note it is the P and I factors that interest us, as follows. How the decoder reacts and controls the compensation system for speed drops etc. can be adjusted. Adjustment of the motor drive characteristics is carried out with the following CVs.

CV150 allows the selection of one of two base motor control algorithms. The CV value range is 0-1.

This corresponds with: CV150=0 Algorithm 1 is in control.
CV150=1 Algorithm 2 is in control.

Each of the two algorithms can be further adjusted by use of their associated CVs.

For more information visit www.hornby.com



Motor control Algorithms: Description

Algorithm 1 (CV150=0)

This algorithm is a non-linear curve which offers lower controlled speed in the low speed end of the curve. This is similar to the Hornby decoder type R8249. CVs 151 & 152 offer control of the P and I factors of the Algorithm 1. Generally speaking, the higher the setting for these two values the motor control becomes 'Stronger' but at the cost of losing fine control. By default this algorithm is set with the P and I values set to 8.

Algorithm 2 (CV150=1)

This algorithm is a linear curve which offers higher controlled speed in the low speed end of the curve. This is similar to some Lenz type decoders. CVs 153 & 154 offer control of the P and I factors of Algorithm 2. By default this algorithm is set with P and I values of 215 and 115 respectively.

Note that CV10 (BEMF cut off) also affects motor control performance.

6. CV Table 2: Engine Sound Transition Configuration

The locomotive's engine sounds will rev up and down and hold at different rev levels (or Notches) depending on the speed step applied from the controller. The system is designed to operate with 128 speed steps (0-127).

Please ensure that your controller is set to support 128 speed stepping (0-127). Not all controllers have the ability to display actual speed step values, in practice this doesn't really affect your driving experience. For the purpose of explanation we will refer to speed steps to explain how the 'engine sounds' react to different throttle levels etc.

The TTS Diesel Sound System... How it works

The decoder in your locomotive is designed to operate at 4 different rev levels. These are the 4 rev levels. Each rev level above 'IDLE' are referred to as 'NOTCH'.

The rev levels...

IDLE (Standing or smallest amount of engine revs.)

NOTCH 1 (Slow Engine Speed)

NOTCH 2 (Medium Engine Speed)

NOTCH 3 (Fast Engine Speed)

The way that the locomotive engine sound responds is controlled by the throttle on your controller i.e. as you increase the actual speed of your locomotive on the track, so the sound responds accordingly. The way the locomotive sounds change can also be controlled by use of certain controller functions (F#).

However, for the moment, we will examine how the engine sound automatically responds under just throttle control. Take a look at the CV table on page 10...

The table indicates configuration of the speed step value that triggers the play of the next NOTCH in the sequence i.e. NOTCH 1 through to NOTCH 3. These are referred to as Trigger Thresholds - TT.

To add further 'realism' to the driving experience we have also added a CV associated with each TT. This is the Trigger Threshold Window - TTW.

In each case, the TTW CV sets a value that is added to the TT value. This creates a window of speed steps values that are used to control the engine sound in a specific way i.e.

- When the speed step transmitted from the controller falls in to the range between TT and TT + TTW the engine sound will NOTCH up and then immediately NOTCH down. Please note that once the speed step transmitted is in this range no further automatic NOTCH Up/Down action will occur until, after the speed step has increased/decreased and then re-entered the TTW.
- This process limits the engine transition lag between minute throttle changes.
- If the speed step transmitted exceeds TT+TTW then the engine will NOTCH up and remain at that NOTCH.

Engine Sound Transitions Configuration

CV	Default	Range	Explanation
	Value	Range	CV Description
CV210	5	5-15	Trigger Threshold 1 - NOTCH 1
CV211	5	5-14	Trigger Threshold Window - 1 This value is added to the setting of CV210 This gives a range of 10 (derived by 5+5) to 29 (derived by 15+14)
CV212	30	25-45	Trigger Threshold 2 - NOTCH 2
CV213	5	5-14	Trigger Threshold Window - 2 This value is added to the setting of CV212 This gives a range of 30 (derived by 25+5) to 59 (derived by 45+14)
CV214	60	60-80	Trigger Threshold 3 - NOTCH 3
CV215	5	5-15	Trigger Threshold Window - 3 This value is added to the setting of CV214 This gives a range of 65 (derived by 60+5) to 95 (derived by 80+15)

Acceleration

Here are some examples using zero as a starting point of how the system responds using the default settings set out in the table above...

- You turn the throttle up until you hear the brake release sound and the locomotive just moves. The speed step applied is less than 5.
Decoder plays the following sequence of engine sounds...
IDLE Only - explanation... if the brakes are released the loco will crawl with the engine idling.
- You turn the throttle up from zero to speed step 8.
Decoder plays the following sequence of engine sounds...
IDLE - Transition to NOTCH 1 - then back to IDLE.
- You turn the throttle up from zero to speed step 12.
Decoder plays the following sequence of engine sounds...
IDLE - Transition to NOTCH 1 - Remains in NOTCH 1.
- You turn the throttle up from zero to speed step 33.
Decoder plays the following sequence of engine sounds...
IDLE - Transition to NOTCH 1 - Transition to NOTCH 2 - then back to NOTCH 1.
- You turn the throttle up from zero to speed step 66.
Decoder plays the following sequence of engine sounds...
IDLE - Transition to NOTCH 1 - Transition to NOTCH 2 - NOTCH 3 - Remains at NOTCH 3
Note: When the locomotive moves off, brake release sounds are played automatically.

For more information visit www.hornby.com



Deceleration

So far we have talked about Acceleration, Deceleration follows different rules. Basically, at any given speed step the appropriate NOTCH or IDLE sound will be playing. On first decrement of the Speed Step the NOTCH playing will transition to the NOTCH below it.

The second decrement of the speed step will cause the system to transition to the next NOTCH downwards. This process will repeat until the sound playing is 'IDLE' and it is not possible to go any lower.

If the throttle is increased after a deceleration event, the acceleration rules will apply as described previously.

Manual Control

In addition to the 'automatic' engine control described previously the decoder also supports 'manual' engine control via Function numbers F5, F6, F7 and F8.

F5 NOTCH UP

F5 is a momentary action control that will force the engine sound to increase to the next NOTCH in the NOTCH sequence. This is possible when IDLE, NOTCH 1 and NOTCH 2 are playing.

Example: If the loco is playing the IDLE sound then pressing F5 once will increase from IDLE to NOTCH 1.

F6 NOTCH DOWN

F6 is a momentary action control that will force the engine sound played to decrease to the next NOTCH in the NOTCH sequence. This is possible when, NOTCH 3, NOTCH 2 and NOTCH 1 are playing.

e.g. If the loco is playing NOTCH 2 sound pressing F6 once will decrease from NOTCH 2 to NOTCH 1.

F7 RETURN TO IDLE

F7 is designated as momentary control action. Once triggered the engine sound will decrease from whatever Notch is currently playing to IDLE playing all engine sound transitions as the engine rev rate drops.

No other control engine function is available until the engine reaches IDLE.

F8 THRASH

F8 is a Toggle function. F8 simulates what happens when the driver 'stamps' on the locomotive's throttle, i.e. the driver applies a lot of power in a sudden burst to overcome a heavy loading situation e.g. when negotiating an incline or moving off with a very heavy load in tow.

The 'Thrash' function increases the current NOTCH by 2 steps. It locks the loco at the new NOTCH until 'toggled' off. When toggled back to 'off' the NOTCH sound played will be appropriate to the current speed of the locomotive. This is to accommodate any acceleration of the locomotives speed during the 'locked' Thrash setting.

Note: F7 'Return to Idle' override F8 'Thrashing'. If F7 is pressed you must ensure F8 is then disabled in order to return to normal engine control...

Example:

- If the loco is playing IDLE, when F8 is toggled on the engine sound will transition and play NOTCH 2
 - If the loco is playing NOTCH 1, when F8 is toggled on the engine sound will transition and play NOTCH 3
 - If the loco is playing NOTCH 2, when F8 is toggled on the engine sound will transition and play NOTCH 3 (one step!)
 - If the loco is playing NOTCH 3, when F8 is toggled on there will be no action
- For further information re driving your locomotive and getting the most out of the sound system see page 3.

7. CV table 3: Spot Sounds Volume Configuration

The volume level of the locomotive 'engine' sounds and each 'spot' sound (e.g. horns etc) is controlled by its own dedicated CV. See table below.

We have set all volume CVs to a default value of 4. This will allow you to hear all sounds clearly. However, how you may want to set the relative balance of the individual sounds differently. It may depend on whether you want to 'hear' the locomotive at a "distance, close up, or possibly when in the driving cab."

In the table below we have added some suggestions re volume levels you may wish to try. These are based on how the locomotive may realistically sound from a scale distance of approximately 15 metres. Remember, these are only suggestions that act as a starting point if you wish to experiment with the relative volume level of each sound...it's up to you!

Volume Settings (Mixer Section)

See 'The Mixer Section' re CV explanations etc.

CV	Default Value	Value Range	F# and Description	Sound Volume Description	Suggested Volumelevels
CV161	4	0-8	F1 Volume	Locomotive Engine Start up/Shut down	4
CV162	4	0-8	F2 Volume	Horn Low-High	6
CV163	4	0-8	F3 Volume	Horn High-Low	6
CV164	4	0-8	F4 Volume	Brake Squeal	1
CV165				Intentionally unused	
CV166	4	0-8	F10 Volume	Compressor	6
CV167	4	0-8	F11 Volume	Door Slam	3
CV168	4	0-8	F12 Volume	Fan	1
CV169	4	0-8	F13 Volume	Horn High Low High	6
CV170	4	0-8	F14 Volume	Horn Low High Low	6
CV171	4	0-8	F15 Volume	Primer	1
CV172	4	0-8	F16 Volume	Slow flange squeal	2
CV173	4	0-8	F17 Volume	Spirax Valve	2
CV174	4	0-8	F18 Volume	Horn Low	6
CV175	4	0-8	F19 Volume	Horn High	6
CV176	4	0-8	F20 Volume	Wagons Buffering	2
CV177	4	0-8	F21 Volume	Wagons Clanging	2
CV178	4	0-8	F22 Volume	Coupling	3
CV179	4	0-8	F23 Volume	Guard's Whistle	4
CV180	4	0-8	F24 Volume	Buffering	1
CV182	Not Readable	0-8		Quick Set Volume level	

Note: For each sound there are 9 possible settings i.e. 0-8. 0 is no sound, while 8 is full volume.

The sound set of the loco has been balanced in the factory so that sounds play at the correct volumes relative to each other. However, individual sounds may be fine-tuned in volume by the user to suit by adjusting their associated CV... Please see table above.

For more information visit www.hornby.com



Setting up volumes using the 'Mixer' Section..

It is recommended that the following CV adjustment procedure is executed in 'Operate Mode' with the loco on the 'Main' track. This is sometimes referred to as 'Programming on the Main'.

Using this programming method greatly speeds up the process of setting the sound balance of the decoder. However, please note you will need to return the loco to the 'Programming Track' and use 'DIRECT CV' Programming mode in order to read back any CV values.

Suggested Sound Volume Set-up Procedure..

Start by setting up the general loco volume level by adjusting CV182 until the volume level of the loco 'start and engine running' sounds are at the desired level.

The sounds on board the loco decoder have been preset in volume to give a "balanced" sound at whatever volume CV182 is set at. However, each individual sound component can now be adjusted in volume to suit.

Using CV table 3, run through the list of 'spot' volumes making any adjustments to their volumes by editing the appropriate CV as necessary.

Note: If you become confused while adjusting the sound volumes the following will assist:

CV8. Apart from the usual 'general reset' function common to all Hornby decoders (CV8=8), on the sound decoder CV8 has a secondary function i.e. writing the value '5' to CV8 will reset all sound volume levels to default levels, i.e. CV161 to CV 180 will be returned to default values i.e. 4. All other CVs will be left as programmed by the user.

Once you are more familiar with the sound volume set up procedure you will find that it is very easy to set a sound volume levels while the locomotive is on the Main track.

This technique allows you to instantly hear the sound volume change as the associated CV is edited. Please see your DCC controller manual re programming in 'Operational Mode' or 'Programming on the Main'.

Note: if you wish to read back any CV setting you must place the loco on the 'Programming Track'. It is not possible to readback CV values in OPERATE mode while a locomotive is on the main track.

8. Decoder Plug and Socket connection specification

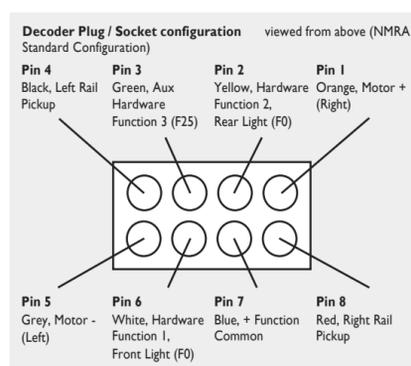

Decoder Current Limits

- Function Output current limits are 100mA per function hardware connection.
- Total Current Draw from decoder is 800mA (motor + functions).
- Decoder can handle 1A peak for short durations. (No Function Load).

Typical example of the configuration of lighting connections regarding function output

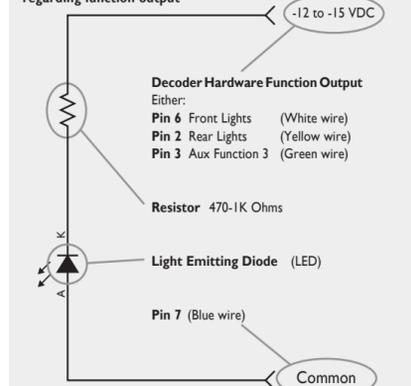

Please note

The Hornby TTS 'Class 60' is fitted with Front/Rear lights that operate under F0 control.

The information above is for general explanation. In the case of the Class 60 only the Aux Function 3 is available for use in any modification of the loco.

For more information visit www.hornby.com



9. Glossary of Function Sounds

Most function sounds are self explanatory. The following additional explanations may be of interest.

Compressor: Charges the air tanks so they are full of compressed air to work the brakes.

Fan: Sometimes called a 'scavenger' fan, this sucks in air from outside the loco to help keep the engine room cool.

Primer: A pump used to remove air from the fuel lines and fill them with diesel, otherwise the engine would not start.

Spirax: A valve fitted to an air tank that makes a ticking noise when the engine is not running to let out any condensation to prevent the tank from freezing.

10. Troubleshooting

No Sound	Turn on sound / Start Engine (F1). The decoder does not support DC running with sound. Reset Decoder. Reset Controller.
Jerky Running	Reset Decoder. Clean Rails / Wheels / Pickups.
No Control or Response from the Locomotive	Check Decoder Address. Reset Decoder. Reset Controller. Clean Rails / Wheels / Pickups.
Locomotive engine does not automatically/manually Notch Up or Down	Is F8 'Thrash' turned on permanently?.. Return F8 to OFF. Note: see page 3 re 'momentary/toggle' control functions. Is the locomotive engine returning to idle after activating F7? (Normal control will resume after approximately 20 seconds.) Please ensure F7 is turned off after operation. Note: see page 3 re 'momentary/toggle' control functions.

For Customer Care contact:
+44 (0)1843 233525
or via website:
www.hornby.com

