

LIST OF SPARES

| Item No. | Description | Pack | R2201/R2054/R2152 | R2103/R2168 | R2059/R2167/R2154 | R2203/R2101/R2089 |
|----------|--------------------------------------|---------|-------------------|-------------|-------------------|-------------------|
| 1 | Valve Gear Set with Screws | 1 | X8425 | X8425 | X8425 | X8425 |
| 2 | Cylinder Block | 1 | X8436 | X8436 | X8437 | X8437 |
| 3 | Coupling Rod Set with Screws | 1 | X8429 | X8429 | X8429 | X8429 |
| 4 | Loco Wheel Set | 1 | X8419 | X8419GN | X8420 | X8419 |
| 5 | Front Bogie Assembly | 1 | X8423 | X8423GN | X8424 | X8423 |
| 6 | Chassis Bottom Assembly (with wires) | 1 | X8431 | X8431 | X8431 | X8431 |
| 7 | Pony Truck Assembly | 1 | X8417 | X8739 | X8418 | X8417 |
| 8 | Close Coupling Assembly (with wires) | 1 | X8432 | X8432 | X8432 | X8432 |
| 9 | Coupling Unit | 2 | X8234 | X8234 | X8234 | X8234 |
| 10 | Ringfield Gear Set | 1 | X8426 | X8426 | X8426 | X8426 |
| 11 | Armature | 1 | X8438 | X8438 | X8438 | X8438 |
| 12 | Ringfield Cover Plate Set | 1 | X8434 | X8434 | X8434 | X8434 |
| 13 | Brush & Spring Pack | 10 + 10 | X8466 | X8466 | X8466 | X8466 |
| 14 | Tender Wheel Set | 1 | X8421 | X8772 | X8422 | X8421 |
| 15 | Tender Underframe Assembly | 1 | X8415 | X8771 | X8416 | X8415 |
| 16 | Drive Unit | 1 | X8798SK | X8798SK | X8800SK | X8798SK |
| 17 | Traction Tyres | 10 | X8439 | X8439 | X8439 | X8439 |
| 18 | Accessories Pack | 1 | X3724 | X3724 | X3724 | X3724 |
| * | Small Parts Pack | 1 | X8427 | X8427 | X8428 | X8428 |

NOTE: All items marked * are contained in small parts pack X8427 and X8428

LOCOMOTIVE ASSEMBLY HINTS

ASSEMBLY HINTS

To aid assembly support each end of the chassis casting.

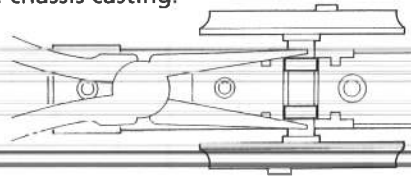

Step 1

Lock Bearings by squeezing bearings inwards with needle nose pliers.

Step 2

Lower the rear wheel assembly. Please note position of the plastic axle box.

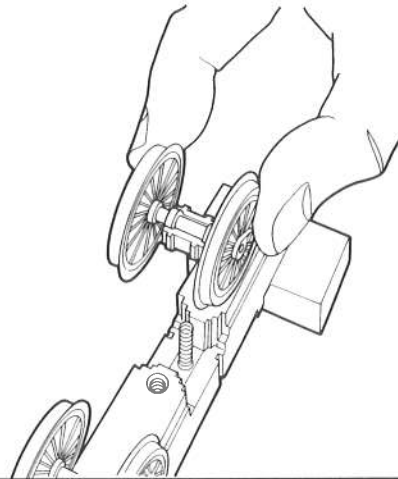

Step 3

Hold the rear axle assembly down and place the chassis bottom rear first onto the chassis. Check the wires and collectors are routed correctly.

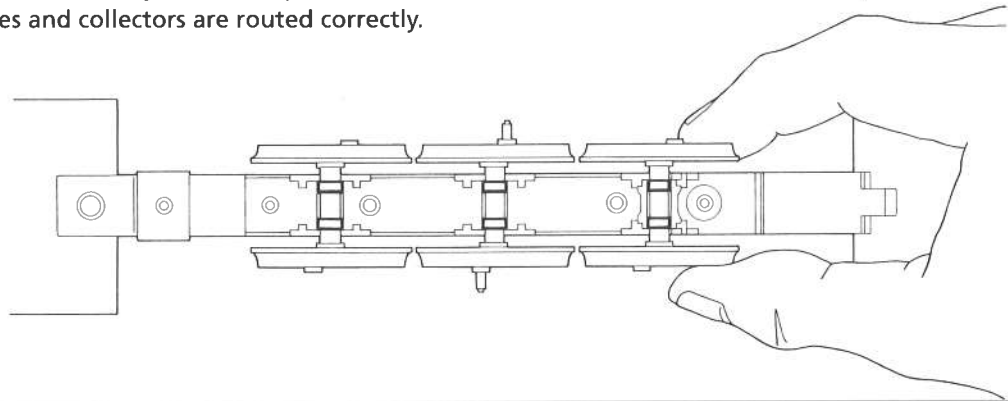

Step 4

After securing the chassis bottom, turn the chassis the right way up and firmly tap on a hard surface to settle the bearings in the chassis.

