

Brake Rods

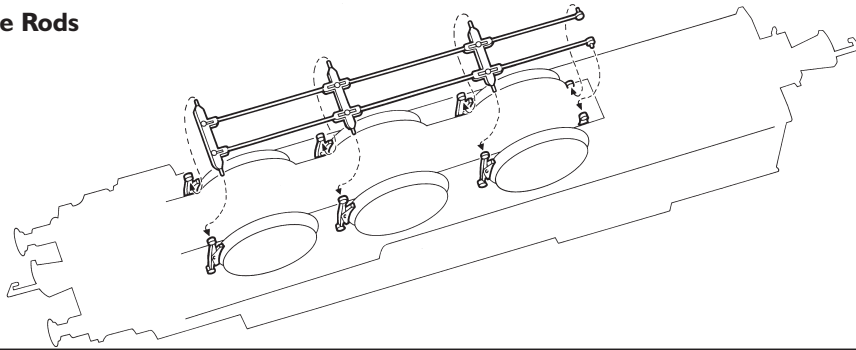

Safety Notes

- This locomotive is not suitable for children under 3 years of age because of small parts which can present a choking hazard. Some components have functional points and sharp edges – handle with care.
- This locomotive is intended for indoor use only.
- The transformer is not a toy. It is a “Transformer for Toys”. Before use, check that the transformer is the correct voltage for your mains electricity supply. This locomotive is only to be used with the recommended transformer. The transformer should be examined regularly for damage to the casing, plug pins and cables. **In the event of such damage, the set should not be used until the transformer is replaced with a new Hornby recommended unit. Never attempt to open the transformer yourself.**
- This locomotive must not be connected to more than the recommended number of power supplies. The output terminals of the transformer must not be connected directly, or indirectly, to the output of any other AC circuit derived from a transformer or mains power supply.
- Before cleaning any part, disconnect the transformer from the mains electricity supply. **Do not use liquid for cleaning.**



Waste electrical products should not be disposed of with household waste. Please recycle where facilities exist. Check with your Local Authority or retailer for recycling advice.

Spare Parts and Service

Spare parts packs can be obtained from Hornby Service Dealers who are also able to offer a repair service.

Hornby Hobbies Limited, Westwood, Margate, Kent CT9 4JX

4/1071A 0508

HORNBY®

Printed in China

IMPORTANT

- **Only remove the locomotive and tender from the packaging by carefully lifting them from the finger holes provided.**
- **This locomotive is made to exacting fine scale standards and therefore necessarily incorporates small, delicate, protruding parts – handle with care.**
- **Before using the model, read through the Operating and Maintenance Instructions in this leaflet.**

HORNBY®



2-6-4T CLASS 4P FOWLER LOCOMOTIVE

Operating and Maintenance Instructions

General

Please read right through these instructions, particularly the Safety Notes on page 4.

Hornby locomotives are precision built and, if treated with care, will give many years of good service. This Hornby locomotive is produced to super detail standard and therefore incorporate delicate, protruding detail and many small parts. Care should be taken to avoid damage when handling the model especially the valve gear, coupling rods and the small detail parts of the locomotive body.

This locomotive should not be operated on track curves of less than 438mm radius, which is Hornby 2nd radius track.

The five-pole electric motor of the locomotive is designed to be operated from a variable 12 volts, DC power supply only. This should be obtained by using a suitable Power Controller operated from the normal domestic mains electricity supply.

NEVER CONNECT A LOCOMOTIVE DIRECTLY TO THE MAINS ELECTRICITY SUPPLY.

The locomotive will normally draw a current of between .2 and .4 amp depending upon the track configuration and whether or not gradients are included. There will be a current surge on starting the locomotive.

Running Hints

If a locomotive ceases to respond normally to the power controller, or runs badly, check that the following are in order:

- All electrical connections are correctly made and the wall power socket is switched “ON”.
- The power connecting clip is correctly inserted into a suitable section of track.
- All track sections are correctly fitted together and all fishplates (rail-joiners) are fitting tightly onto adjoining metal rails.
- All locomotive wheels are correctly positioned on the track rails.
- The tender drawbar pin is making contact with the contacts on the locomotive drawbar and the upper contacts of the drawbar are making contact with the drawbar pin plate of the tender (if applicable).
- The direction control switch on the train controller is set to operate in one direction or the other, and not in the central “OFF” position.

Television Suppression

Your Hornby locomotive incorporates radio and television interference suppressors. Should interference be experienced despite these precautions, it may be due to close proximity of the model railway layout to receivers, aerials, or their “downlines”. In this case, move the layout further away from aerials and receivers.

It is most important that track and wheels be kept absolutely clean.

DCC Ready – contact your specialist dealer for advice.

Routine Maintenance

Track Cleaning – In normal use, model railway layouts will eventually accumulate a blackish deposit on the running surfaces of the rails, and some of this will be transferred onto the locomotive’s pick-up wheels.

The 12 volt DC supply is collected from the track through the wheels on one side of the locomotive and returned through the wheels on the other side. If the deposit is allowed to build up, it will have the following adverse effects:

- The driving wheels will not be able to achieve maximum traction
- There will be a reduction in the power reaching the locomotive motor

It is therefore essential that the track and wheels are kept clean. This can be done by wiping the surfaces with a clean, non-fluffy cloth. More stubborn deposits can be removed by using the Hornby Track Cleaning Rubber, reference R8087, which can be obtained from Hornby Service Dealers.

Motor – The locomotive is fitted with a sealed, long-life, 5-pole motor which requires no maintenance. After a considerable amount of use the motor may require replacement and this should be carried out by a Hornby Service Dealer. However, instructions for motor replacement are given in Section 4 on page 3, only for owners who are fully experienced in such tasks and who have soldering facilities. Do not attempt this work unless you are absolutely confident in being able to successfully complete it.

Chassis – The locomotive chassis may, from time to time, pick up fluff, fabric fibres and pet hairs which can become entangled in the gears and around axles. For this reason, it is not advisable to run the locomotive on track which is laid on a carpet. It is important to check regularly and remove any such debris with the aid of small tweezers.

Lubrication – Although the locomotive was lubricated during manufacture, the lubricant can sometimes dry out in storage. Lubrication should be carried out at approximately 6-monthly intervals, or every 100 hours of running. Instructions for carrying out lubrication procedures are given in section 1 on page 2.

Locomotive Bodywork – Locomotive and tender bodies are overall spray painted and the rest of the decoration is applied by a printed process, not transfers.

1 Lubrication

IMPORTANT – Only apply small single drops of light machine oil to the places indicated in red. This is best achieved by making a simple oil “dropper” as illustrated in Fig. 1. Insert a straightened paper clip into a cork and use a bottle cap as a container for the oil. A small drop of oil can then be picked up by the dropper and applied in exactly the right place. Immediately wipe off any excess oil, especially from the locomotive and tender bodies. Only lubricate moving parts.

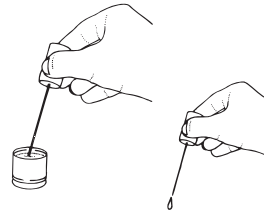
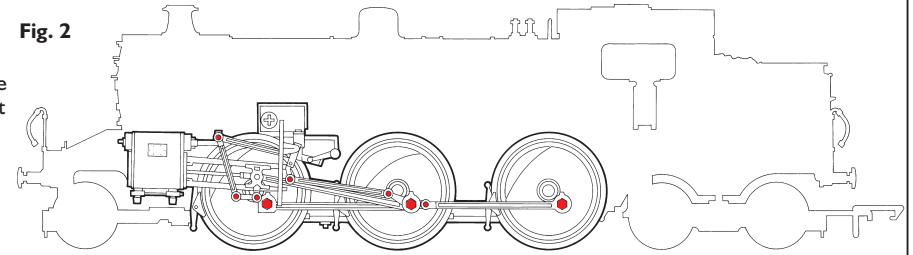

Fig. 1

Apply one drop of oil to each of the valve gear and connecting rod pivot points indicated in red in Fig. 2, on both sides of the locomotive.

Fig. 2



2 Accessories

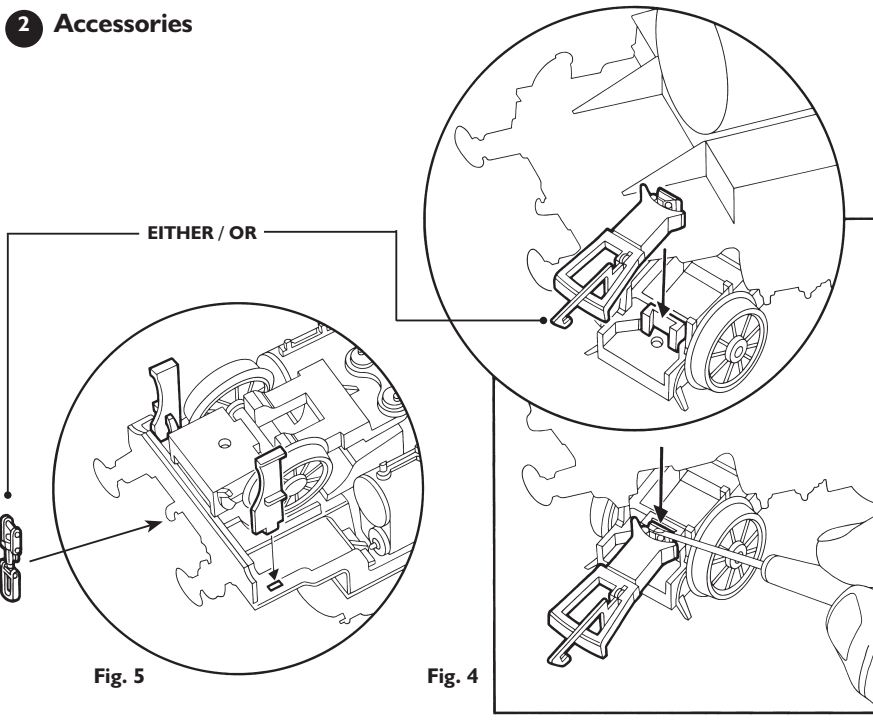

Apply one drop of oil to each of the axle bearings indicated in red. (See Fig. 3).

Fig. 3

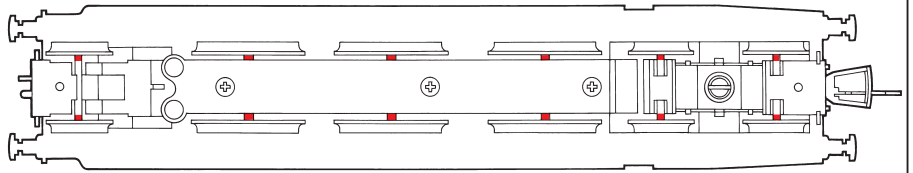
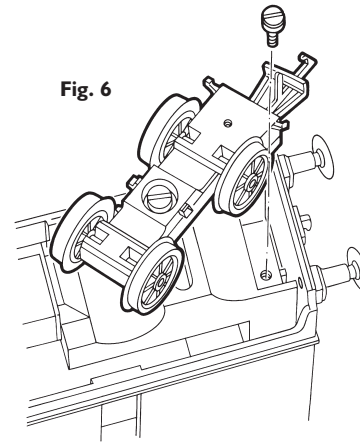

Fig. 6



3 To remove the locomotive body

Turn the locomotive upside down and remove the screw from the rear bogie. (Fig. 6). Turn the locomotive the right way up and ease the rear end of the chassis downwards from the body. When the rear of the chassis is clear of the body, pull the chassis backwards to disengage the front chassis lugs from the front of the body. (Fig. 7)

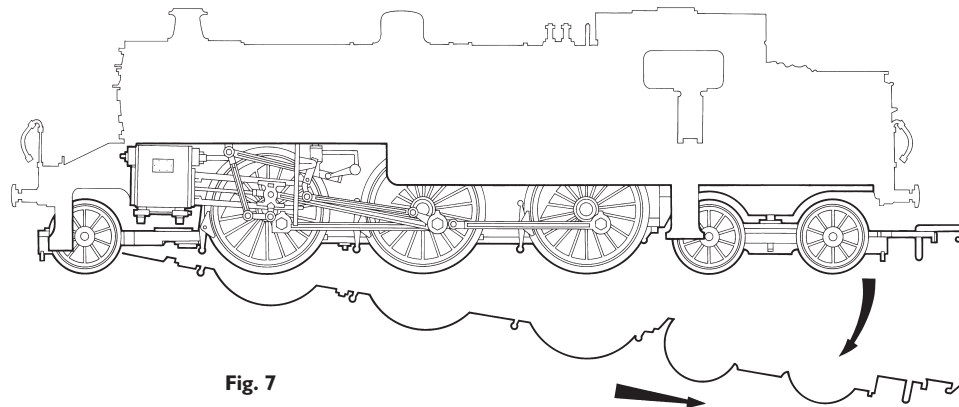
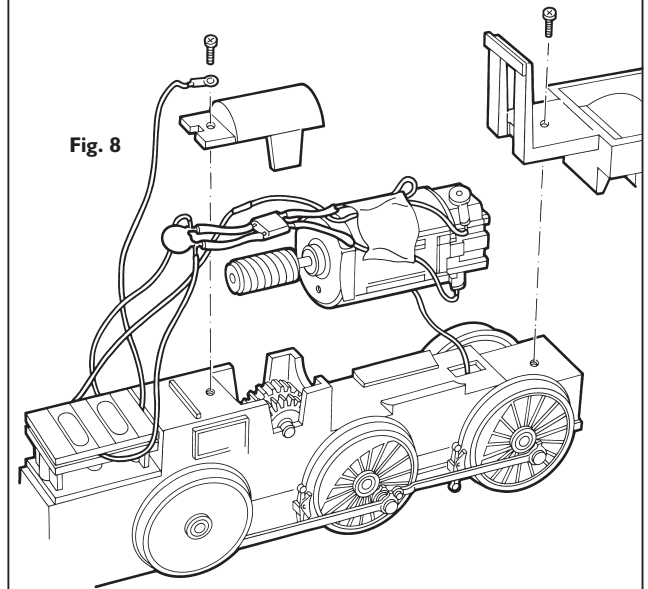

Fig. 7

4 To replace the locomotive motor

Remove the front and rear motor bracket screws. The motor can now be lifted clear and replaced. (Fig. 8).

Fig. 8



When fitting the replacement motor, make sure the worm and worm wheel are meshed correctly before screwing the motor bracket back in place.